

ASSEMBLY INSTRUCTION

SH2214F-1 FULL BED

Thank you for purchasing this product. Please take time to read and follow the instructions below. Check that you have all parts and hardware before assembly. Parts apparently missing are often found in the packing materials. If you do not have all the parts listed, have your dealer contact us and they will be sent to you immediately.

⚠ It is recommended to install protective pads under all legs and supports to avoid damage or scratches when placing furniture on a wood floor or other hard surface, and to limit indentation and prevent discoloration if placing on carpet.

PARTS LIST			
ITEM	DESCRIPTION	SKETCH	QTY
A	HEADBOARD		1 PC
B	HEADBOARD LEG (L)		1 PC
C	HEADBOARD LEG (R)		1 PC
D	FOOTBOARD		1 PC
E	SIDE RAIL (i)		2 PCS
F	SIDE RAIL (ii)		2 PCS
G	SLAT		4 PCS
H	CENTRE SUPPORT LEG		4 PCS
I	SIDE RAIL SUPPORT LEG		2 PCS

HARDWARES LIST			
ITEM	DESCRIPTION	SKETCH	QTY
1	JCBB SCREW (M8 x 20MM)		8 PCS
2	JCBB SCREW (M8 x 25MM)		8 PCS
3	JCBB SCREW (M8 x 35MM)		6 PCS
4	JCBC SCREW (M6 x 35MM)		4 PCS
5	SPRING WASHER (M8 x 14MM)		14 PCS
6	FLAT WASHER (M8 x 22MM)		14 PCS
7	CSK SCREW (M4 x 32MM)		8 PCS
8	ALLEN KEY (M4 x 65MM)		1 PC
9	ALLEN KEY (M5 x 65MM)		1 PC

STEP 1

This step needs to be done four times.

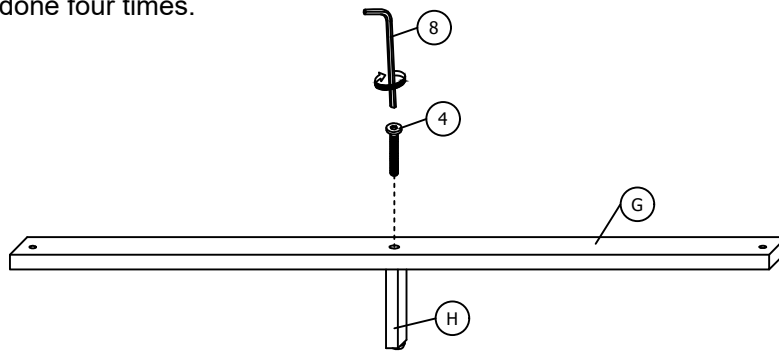

STEP 2

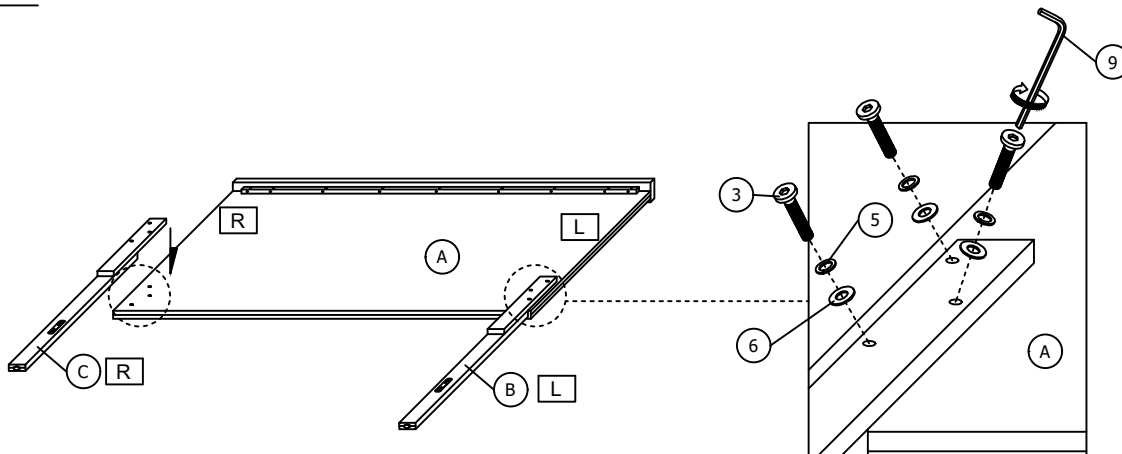

****DO NOT TIGHTEN BOLTS UNTIL COMPLETELY ASSEMBLED**

ASSEMBLY INSTRUCTION

SH2214F-1 FULL BED

STEP 3

This step needs to be done twice.

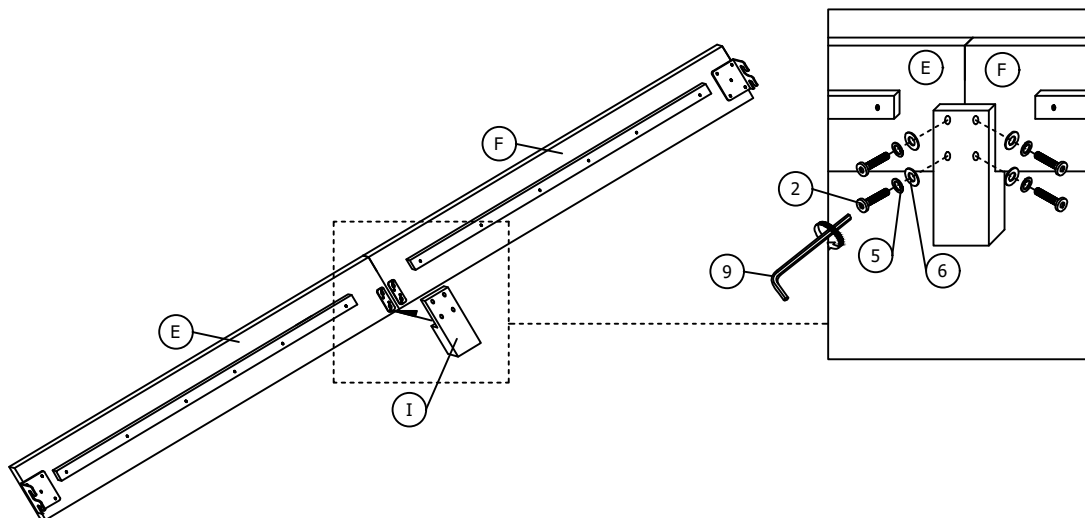

STEP 4

STEP 4.1 : Insert but do not tighten item (1).

STEP 4.2 : Put item (E)&(F) on item (B),(C) and (D).

STEP 4.3 : Tighten item (1).

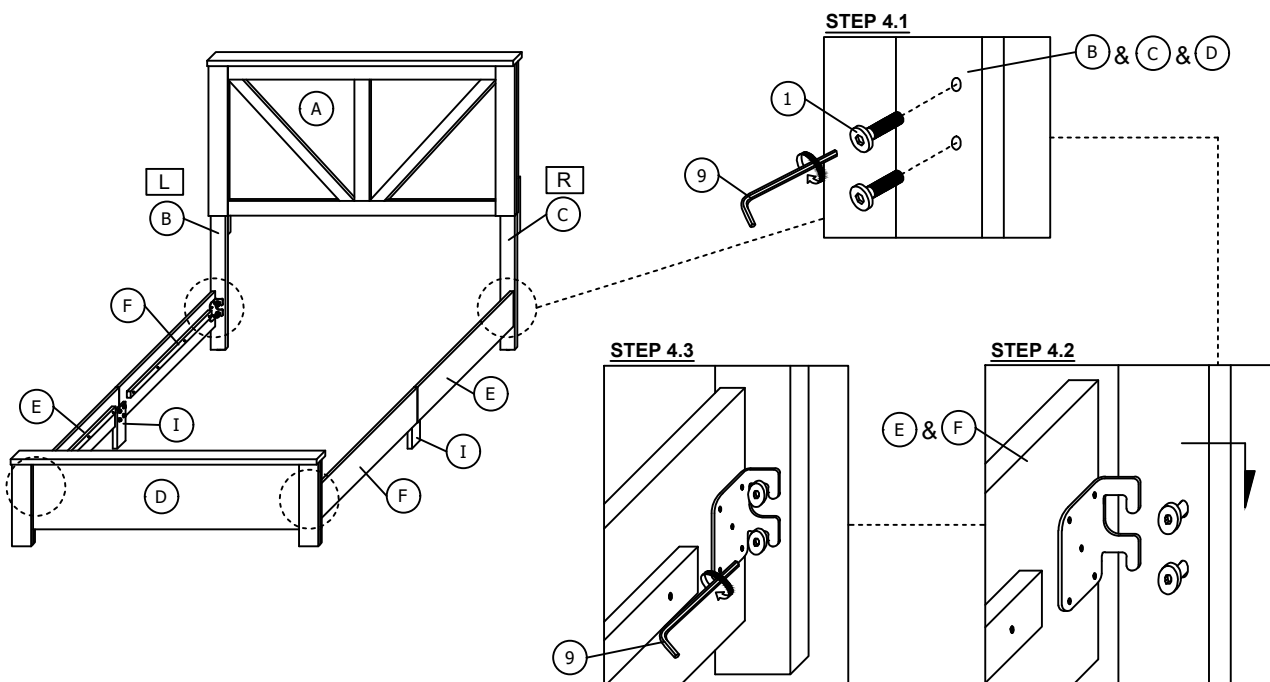

ASSEMBLY INSTRUCTION

SH2214F-1 FULL BED

STEP 5

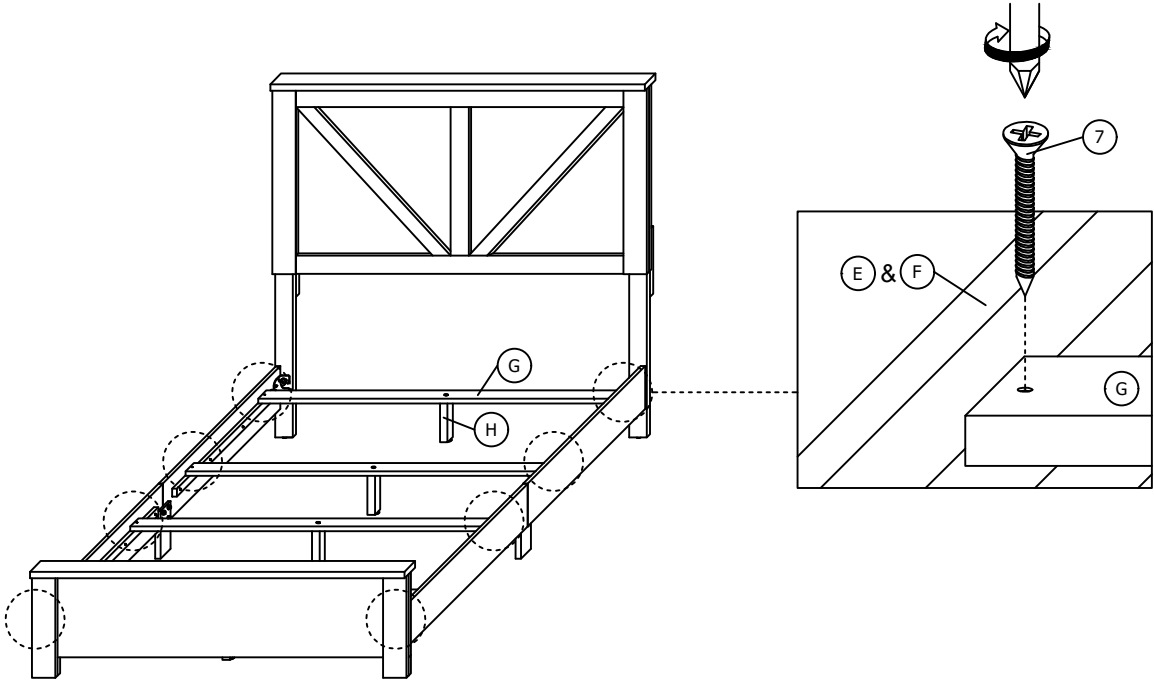

STEP 6

