



ASSEMBLY INSTRUCTION INSTRUCTIONS D'ASSEMBLAGE

ITEM NO : 2469 - 5

DRESSER / BUREAU DOUBLE

Thank you for purchasing this product. Please take time to read and follow the instruction below. Check that you have all parts and hardware before assembly. Parts apparently missing are often found in the packing materials. If you do not have all the parts listed, have your dealer contact us and they will be sent to you immediately.

Merci d'avoir achete ce produit. Veuillez lire et suivre les instructions ci-dessous. Verifiez avant le montage que vous avez toutes les pieces et fixations. Les pieces qui semblent manquer se trouvent souvent dans les materiaux d'emballage. Si vous n'avez pas toutes les pieces de la liste, demandez a votre detailliant et nous vous les enverrons immediatement.



! It is recommended to install protective pads under all legs and supports to avoid damage or scratches when placing furniture on a wood floor or other hard surface, and to limit indentation and prevent discoloration if placing on carpet.

! Il est recommande de placer des coussins protecteurs sous tous les pieds et toutes les bases des meubles pour eviter d'endommager ou d'egrantigner les planchers en bois ou autres surfaces dures, et pour limiter l'empreinte et empecher la decolorations quand les meubles reposent sur la moquette.

! Hardware may loosen over time. Periodically check to make sure all connections are tight. Re-tighten if necessary.

! Le matériel peut se desserrer au fil du temps. Vérifiez périodiquement que toutes les connexions sont serrées. Serrer à nouveau si nécessaire.

2469-5 PARTS LIST / LISTE DE PIÉCES

NO/No	DRAWING/DESSIN	DESCRIPTION	QTY/QTÉ
1		DRESSER / BUREAU DOUBLE	1PC

HARDWARE LIST / LISTE DE QUINCAILLERIE

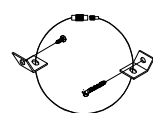
NO/No	DRAWING/DESSIN	DESCRIPTION	QTY/QTE
A		TIPPING RESTRAINT / ANTI-BASCULEMENT	1 SET

*ABOVE HARDWARE ARE PACKED IN 2469-5 FOR ASSEMBLY.

* NOTE : YOU WILL NEED A PHILLIP SCREWDRIVER (NOT PROVIDED) / VOUS AUREZ EGALAMENT BESOIN D'UN TOURNEVIS PHILIP (NON FOURN)

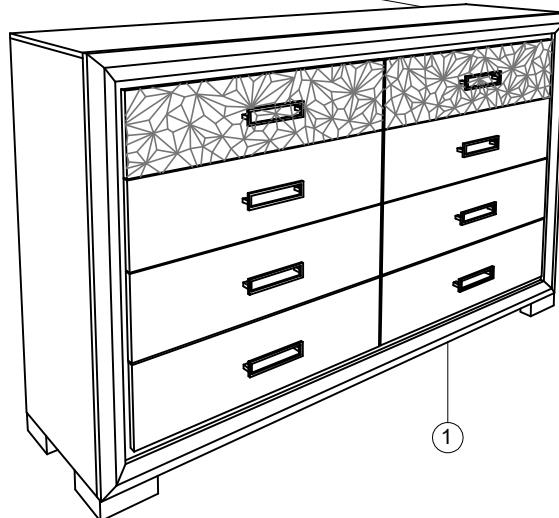
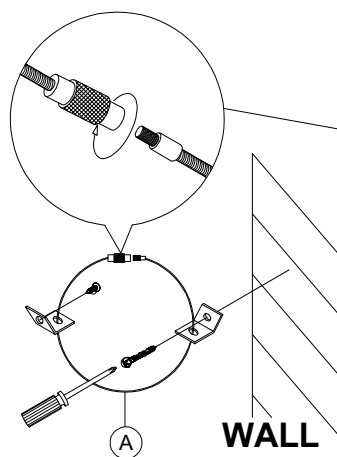

! NOTE

Tipping restraint hardware kit is included with this product. Refer to insallation instruction in the hardwarer pack.

*ANTI-TIPPING HARDWARE PACK IS AT THE BACK PANEL.

! NOTE / REMARQUE

* DO NOT TIGHTEN BOLTS UNTIL COMPLETLY ASSEMBLED.
NE PAS SERRER LES BOULONS JUSQU'A CE QUELE MONTAGE SOLT COMPLETMENT TERMINE.

COMPLETED / COMPLETÉ